

© 1958 BY AMP INCORPORATED. ALL RIGHTS RESERVED. AMP PRODUCTS COVERED BY PATENTS AND/OR PATENTS PENDING. APPROVED PER GOVT CONTRACT NO.

REVISIONS				
SYM	ZONE	DESCRIPTION	DATE	APPROVAL
B		REDRAWN w/6 CHANGE		
BI		REV PER ECR 05-013140	10/24/68	DR/TM

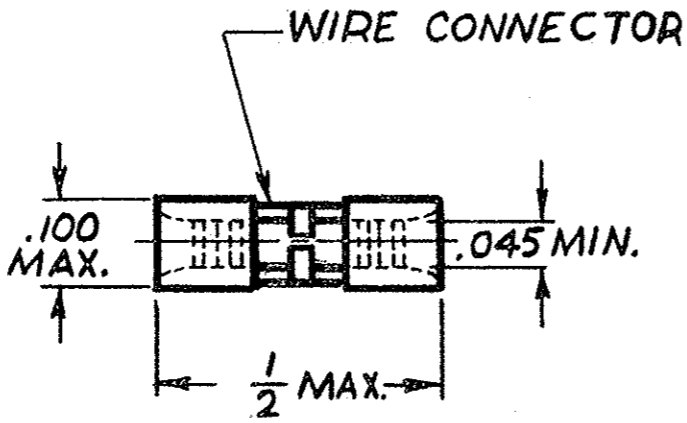
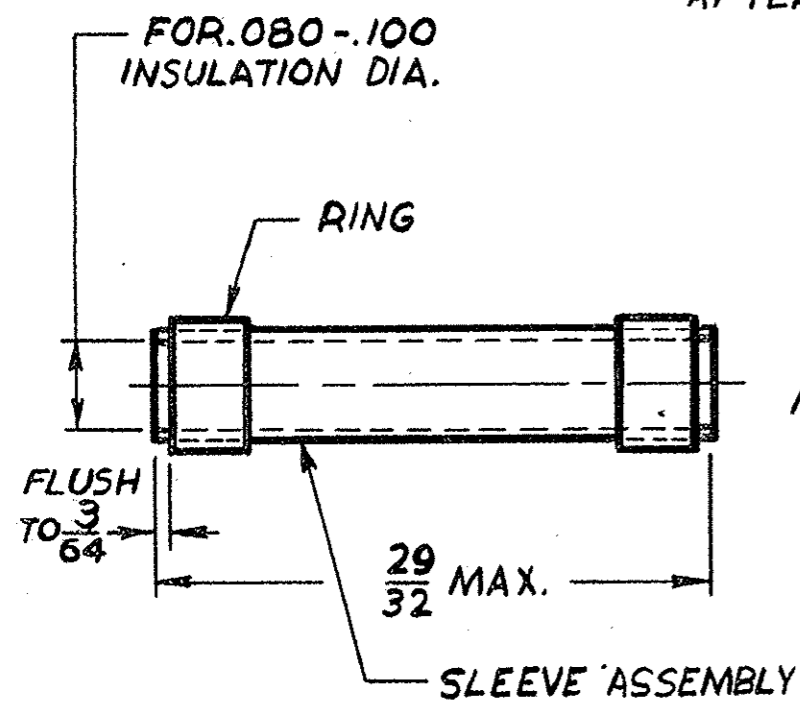
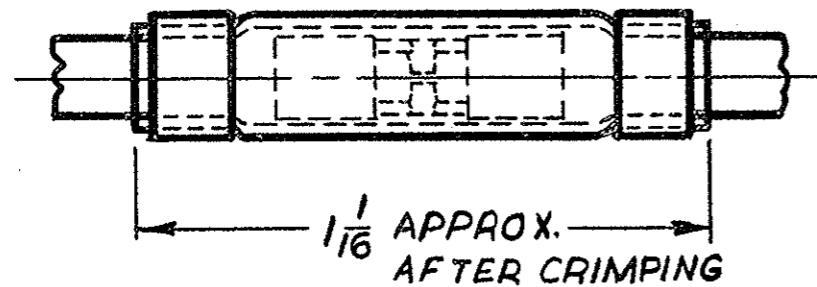

1	SLEEVE ASSEMBLY	326769	RING: COPPER (QQ-C-576), NICKEL PLATED (QQ-N-290) INSULATION: TEFLON (ASTM D3295)
1	WIRE CONNECTOR	326745	COPPER (QQ-C-576), WITH SILVER PLATING (QQ-S-365)

AMP INFO				QTY REQD	NOMENCLATURE OR DESCRIPTION	PART OR IDENTIFYING NO.	MATERIAL AND PLATING
LOC	PRINT DIST	WIRE SIZE					
G	14	B	22-20				

UNLESS OTHERWISE SPECIFIED DIMENSIONS ARE IN INCHES TOLERANCES ON		
FRACTIONS	DECIMALS	ANGLES
± 1/64	± .008	± 5°
MATERIAL SEE TABLE		
HEAT TREAT H		
FINISH SEE TABLE		

SIGNATURE		DATE
DR	<i>L.C. Conley</i>	5/11/65
CHK	<i>M. Snyder</i>	5/12/65
DSGN ENGR		
APPD	<i>Bell</i>	5/13/68
DSGN APPD		
OTHER APPD		

		AMP INCORPORATED HARRISBURG, PENNSYLVANIA	
		NAME WIRE SPLICE POST-INSULATED STRATO-THERM BUTT	
CODE IDENT NO	SIZE	NUMBER	
00779	B	326835	
SCALE 3:1	WT	CALC	ACTUAL
			SHEET 1 OF 1